



better together

Data sheet

DGE 100/2/G50H A0CM5

E

series

Technical specification

1~ 50 Hz

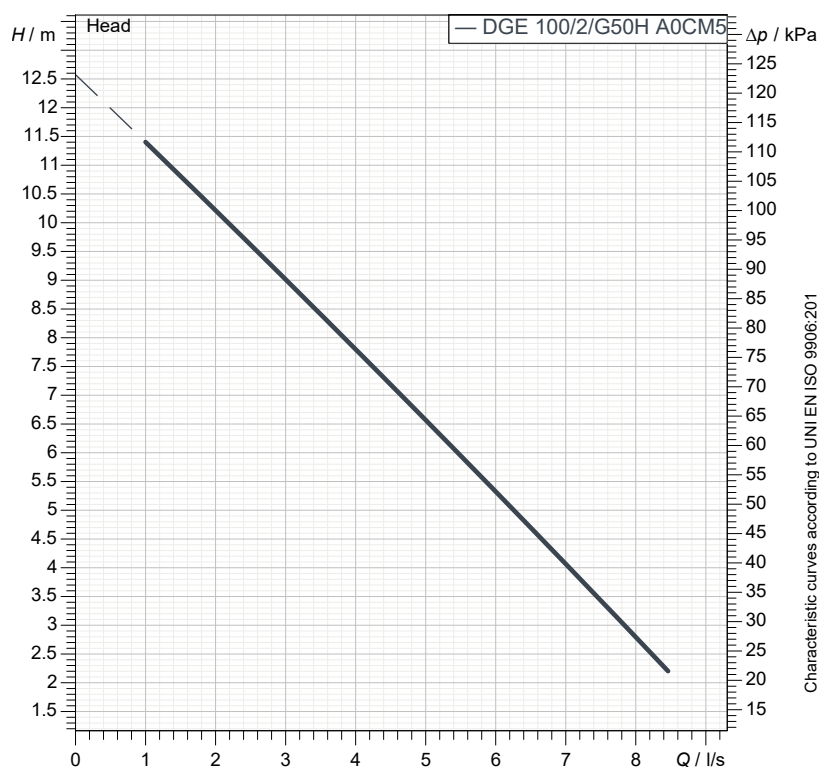

Characteristic curves according to UNI EN ISO 9906:201
P2 < 10kW: paragraph 4.4.2
10kW < P2 < 100kW: Grade 3B
P2 > 100kW: Grade 2B

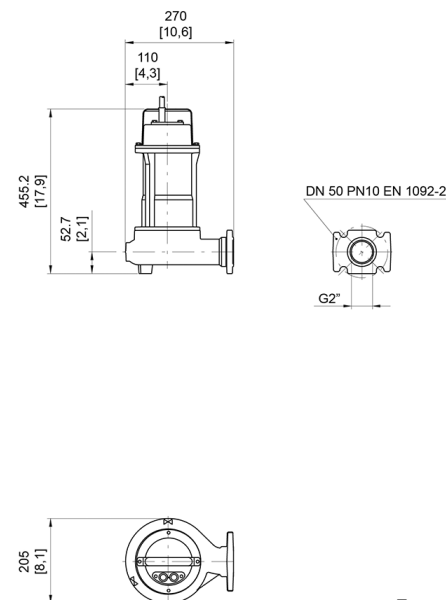

[mm]
[inch]

Pump

Series	E series
Pump name	DGE 100/2/G50H A0CM5
Configuration	NGTGQ21023N00NN
Standard	EN 809:2009

Motor data

Rated voltage	230 V
Frequency	50 Hz
Motor phases	1~
Number of poles	2
Rated power P2	0.9 kW
Incoming power P1	1.4 kW
Rated current	6.0 A
rpm	2900 1/min
cos φ	0.96
Rated torque	2.9 Nm
Start	
Degree of protection	IP 68
Insulation class	F

Hydraulic

Type	DG (Set-back Vortex)
Free passage	50 mm
Impeller type	Set-back Vortex impeller
Discharge	DN 50 - G2" EN 1092-2
Curve tolerance	UNI EN ISO 9906:2012

Operating limits (standard pumps)

Max. ambient temperature	40 °C
Max. density treated liquid	1100 kg/m³
pH treated liquid	6 ÷ 14
Max. start per hour (equally distributed)	30
Wet/dry use	WET
Max. acoustic pressure level	70 dB
Operating mode	S1 - Continuous use

Construction materials

Case	Cast iron EN-GJL 250
Shaft	Stainless steel AISI 431
Hydraulic	Cast iron - EN-GJL 250
Impeller	Cast iron - EN-GJL 250
Painting/Coating	Bi-epoxy 120 μm
Screws	Stainless steel - Class A2-70
Gaskets	NBR

Construction features

Main cable	3G1
Control cable	-
Cable length	10 mt
Mechanical seals	1 in silicon carbide and 1 lip seal
Additional drilling	-
Weight*	19 kg
Electrical variant	Thermal protection, capacitor and float switch (on the motor cover)

* cable and fixing system excluded



better together

Data sheet DGE 100/2/G50H A0CM5

E series

Pump performance curves

1~ 50 Hz

Hydraulic type DG (Set-back Vortex)	Impeller type Set-back Vortex impeller	Free passage 50 mm	Discharge DN 50 - G2"	Suction -	
DUTY POINT					
Flow	Head	Shaft power P2	Hydraulic efficiency	Density 998.3 kg/m ³	Viscosity 1.005 mm ² /s

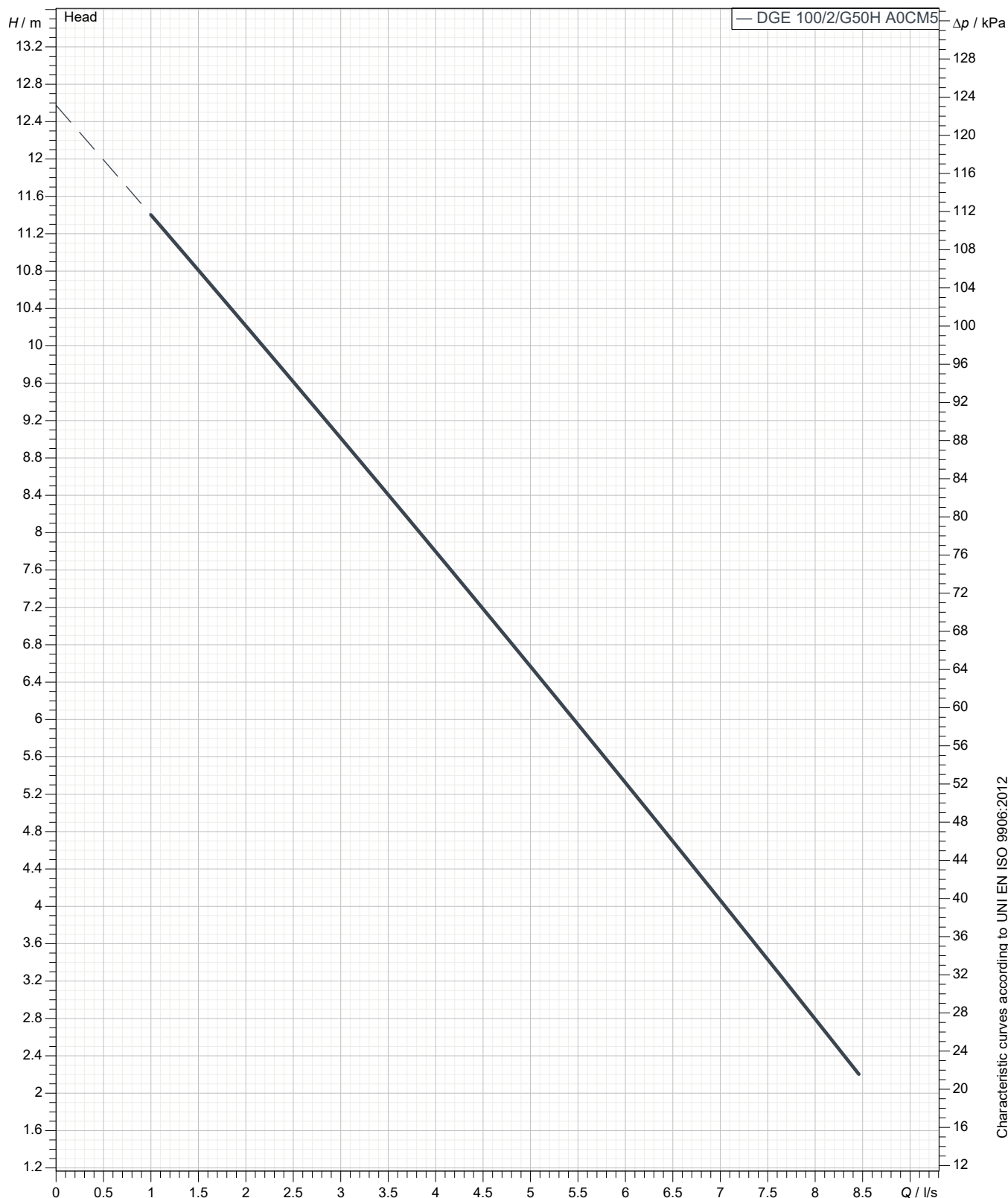

Characteristic curves according to UNI EN ISO 9906:2012
 P2<10kW: paragraph 4.4.2
 10kW<P2<100kW: Grade 3B
 P2>100kW: Grade 2B



better together

Data sheet

DGE 100/2/G50H A0CM5

E
series

Dimensional drawing

1~ 50 Hz

Installation type Installation with bottom coupling device - Vertical outlet + GTP

WET/DRY use: WET

Accessory * : DAC 32-50/G50V-G65V 3/4" EN+GTP (P)

Discharge: DN 50 - G2" EN 1092-2

Accessory code * : 9028.002

Pressure rating (suction/discharge): PN 10

* Accessory must be ordered separately

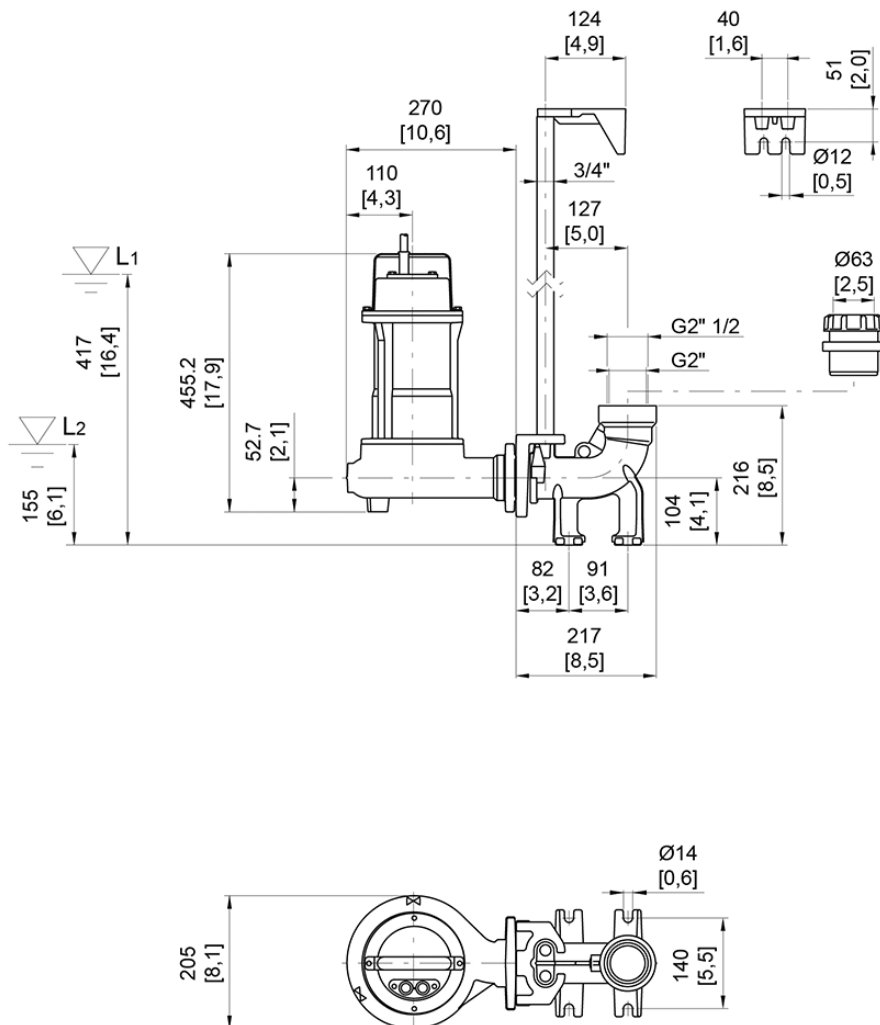

L1: Minimum operating level for continuous use
L2: Minimum operating level for discontinuous use

[mm]
[inch]